

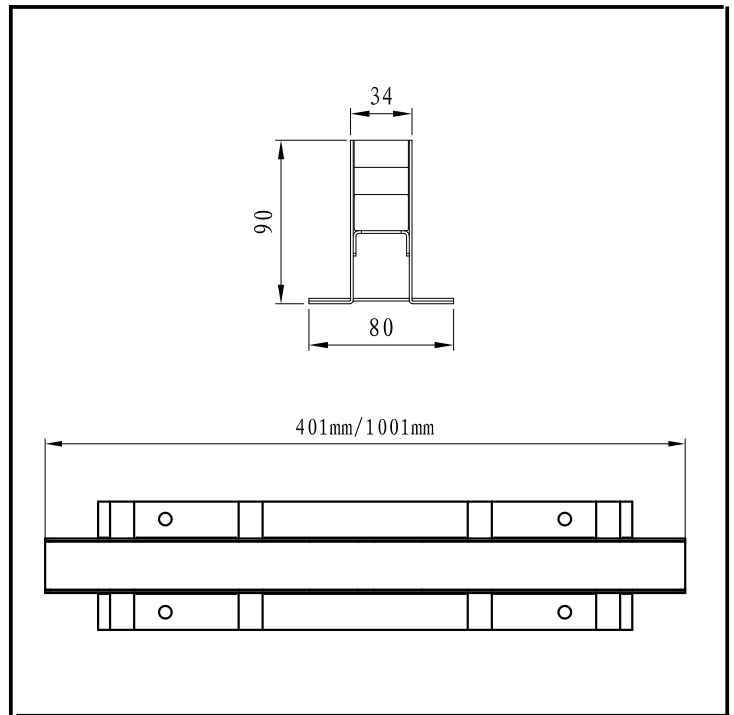

M-212



Product Model:	M-212L400-LED9.2-49	M-212L1000-LED23-126
IP Protection degrees:	IP67	
IK Protection degrees:	IK09	
Light source:	49 x SMD 2835	126x SMD 2835
Total power consumption:	9.2W	23W
Luminous Flux:	570-644Lm	1380-1610Lm
Luminous efficiency:	60-70Lm/w	
Color temperature:	4000K as standard. Optinal 2700K,3000K & 5700K. Amber LED available	
Voltage/Frequency:	24V DC	
Warranty(Years):	5	
Units per box:	1	
Net Weight(Kg)	2.2	5.4



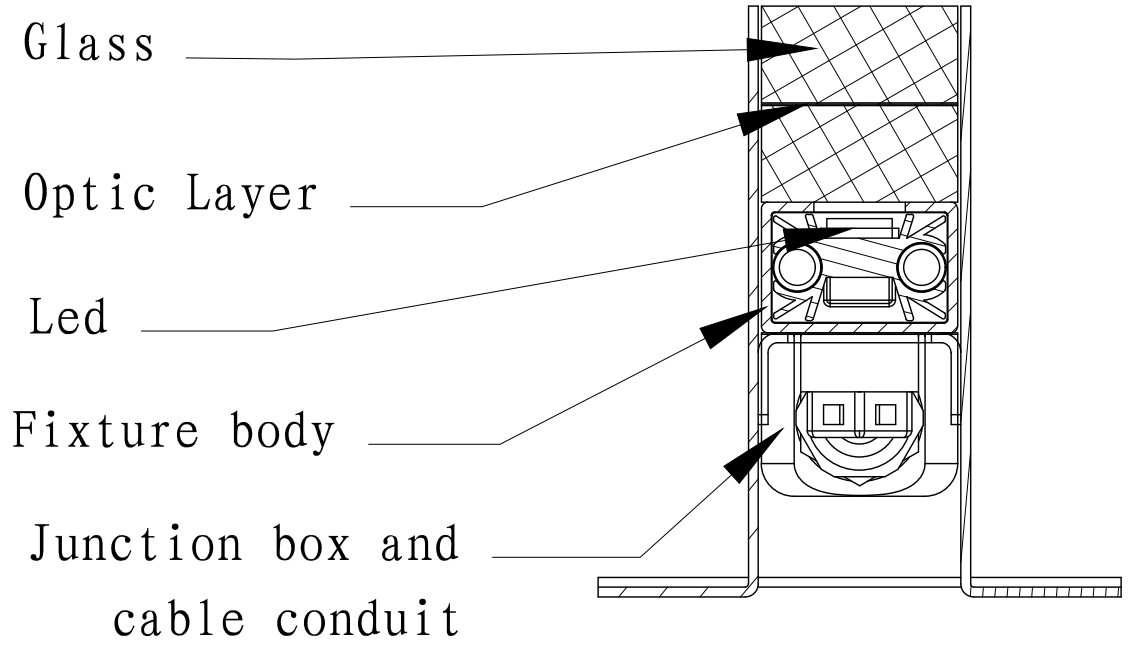
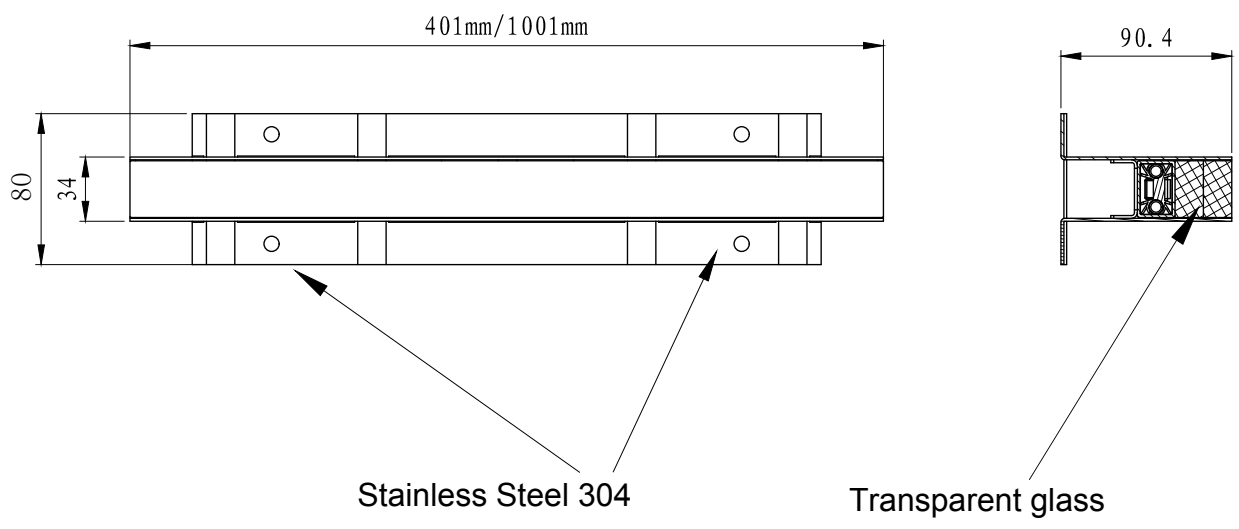

Installation template

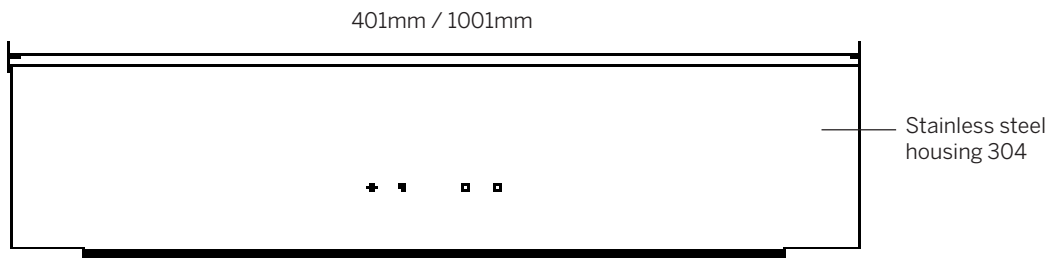
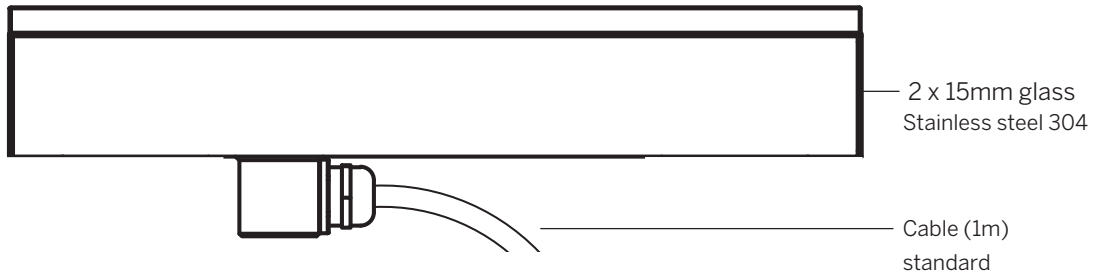

Side view

### Installation template